



## Technical comercial data

# CU-3.3-UN T.CU-6.3

Serie CUBETA – Versión 14-02-2024

Approved UN 4H2/Y3.5/S Group II and III solids with inner bag,  
marked with a danger triangle for blind people.

## TECHNICAL DATA:

Material:	PP copolymer of first quality.
Colours:	White standard. Consult for other colours.
Useful Volume:	3.3 litres
Volume to the edge:	3.7 litres
Weight of the rectangular bucket:	126 g. approx.
Weight of the lid:	56 g. approx.
Weight of the handle (plastic):	6 g. approx.
Total Weight:	188 g. approx.



Design surface photographic finish: 80 x 620 mm (altura x perímetro).

## MEASUREMENTS:

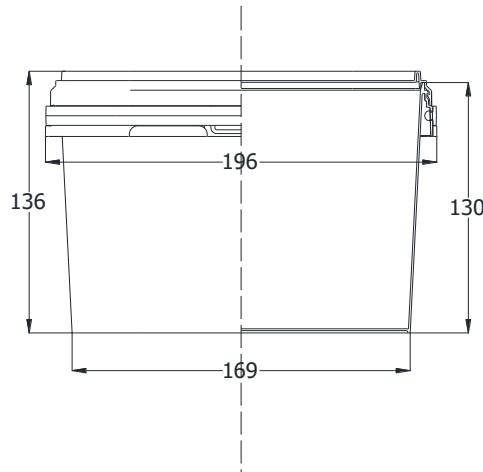

Measurements in millimetres

## GROUPING OF TRANSPORT:

Rectangular buckets: 1080 rectangular buckets per pallet  
Pallet dimensions: 1180 x 979 x 1210 (see drawing)

Lids: 180 lids per box, this serves as a  
packaging of transportation

Box dimension: 445 x 210 x 915

